



深圳市拓普微科技开发有限公司

SHENZHEN TOPWAY TECHNOLOGY CO., LTD.

LM6800ACW-1

LCD Module User Manual

Prepared by: Wang Date: 2018-12-14	Checked by: Date:	Approved by: Date:
---	----------------------------------	-----------------------------------

Rev.	Descriptions	Release Date
0.1	Preliminary New release	2017-04-19
0.2	Revise AC Characteristics	2018-12-14

Table of Content

1. Basic Specifications	3
1.1 Display Specifications	3
1.2 Mechanical Specifications	3
1.3 Block Diagram.....	3
1.4 Terminal Functions.....	4
2. Absolute Maximum Ratings	5
3. Electrical Characteristics	5
3.1 DC Characteristics	5
3.2 LED Backlight Circuit Characteristics.....	5
3.3 AC Characteristics	6
4. Function Specifications	7
4.1 Basic Setting	7
4.2 Adjusting the LCD display contrast	7
4.3 Resetting the LCD module	7
4.4 Display Memory Map	8
4.5 Internal Registers.....	8
4.6 Display Control Instructions	9
5. Design and Handling Precaution	10

1. Basic Specifications

1.1 Display Specifications

- 1) LCD Display Mode : FSTN, Positive, Transmissive
- 2) Display Color : Display Data = "1" : Dark Gray (*1)
: Display Data = "0" : Light White (*2)
- 3) Viewing Angle : 6 H
- 4) Driving Method : 1/64 duty, 1/9bias
- 5) Back Light : White LED backlight

Note:

*1. Color tone may slightly change by Temperature and Driving Condition.

*2. The Color is defined as the inactive / background color

1.2 Mechanical Specifications

- 1) Outline Dimension : 137.0 x 39.6 x 11.3MAX
(see attached Outline Drawing for details)

1.3 Block Diagram

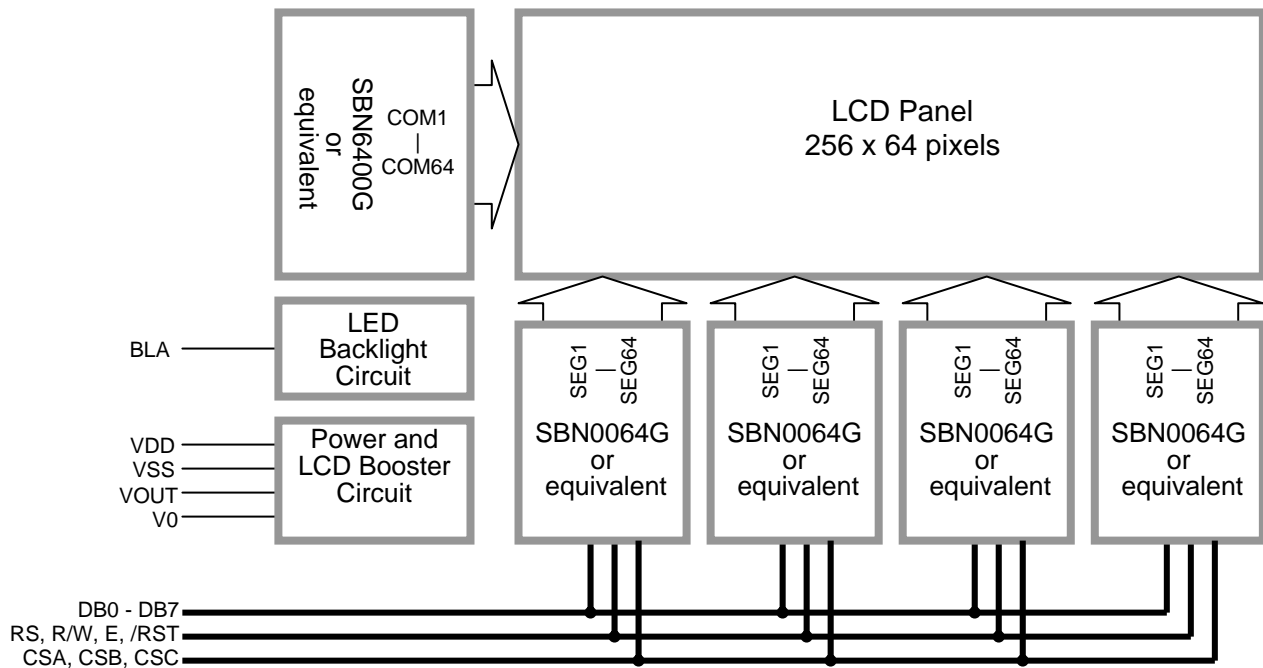

1.4 Terminal Functions

Pin No.	Pin Name	I/O	Descriptions																								
1	VSS	Power	Negative Power Supply, Ground (0V)																								
2	VDD	Power	Positive Power Supply																								
3	V0	Input	LCD Contrast reference																								
4	VOUT	Output	Power Booster output for V0																								
5	RS	Input	RS = H; DB0 – DB7 = Display RAM data RS = L; DB0 – DB7 = Instruction data																								
6	R/W	Input	In read mode R/W = H; Data read from the LCD module, data appears at DB0 – DB7 and can be read by the host while, E = H and the device is being selected In write mode R/W = L; Data write to the LCD module, data appears at DB0 – DB7 will be written into the LCD module at E = H→L and device is being selected																								
7	E	Input																									
8	DB0	I/O	Data bus: Three state I/O terminal for display data or instruction data																								
:	:	:																									
15	DB7	I/O																									
16	CSA	Input	Chip selection, enable access to each section of the LCD module <table border="1" style="width: 100%; border-collapse: collapse;"> <thead> <tr> <th>CSC</th> <th>CSB</th> <th>CSA</th> <th>Function</th> </tr> </thead> <tbody> <tr> <td>0</td> <td>0</td> <td>0</td> <td>Enable access of the Left-Most Section (64 column) of the LCD module</td> </tr> <tr> <td>0</td> <td>0</td> <td>1</td> <td>Enable access of the Middle-Left Section (64 column) of the LCD module</td> </tr> <tr> <td>0</td> <td>1</td> <td>0</td> <td>Enable access to the Middle-Right Section (64 column) of the LCD module</td> </tr> <tr> <td>0</td> <td>1</td> <td>1</td> <td>Enable access to the Right-Most Section (64 column) of the LCD module</td> </tr> <tr> <td>1</td> <td>x</td> <td>x</td> <td>Disable all the access to the LCD module</td> </tr> </tbody> </table>	CSC	CSB	CSA	Function	0	0	0	Enable access of the Left-Most Section (64 column) of the LCD module	0	0	1	Enable access of the Middle-Left Section (64 column) of the LCD module	0	1	0	Enable access to the Middle-Right Section (64 column) of the LCD module	0	1	1	Enable access to the Right-Most Section (64 column) of the LCD module	1	x	x	Disable all the access to the LCD module
CSC	CSB	CSA		Function																							
0	0	0		Enable access of the Left-Most Section (64 column) of the LCD module																							
0	0	1		Enable access of the Middle-Left Section (64 column) of the LCD module																							
0	1	0		Enable access to the Middle-Right Section (64 column) of the LCD module																							
0	1	1		Enable access to the Right-Most Section (64 column) of the LCD module																							
1	x	x	Disable all the access to the LCD module																								
17	CSB	Input																									
18	CSC	Input																									
19	/RST	Input	Reset signal /RST = L, Display off display start line register becomes 0 no command or instruction data could be accepted /RST = H, Normal running																								
20	BLA	Power	Positive Power Supply for LED backlight																								

2. Absolute Maximum Ratings

Items	Symbol	Min.	Max.	Unit	Condition
Supply Voltage	V_{DD}	0	7.0	V	$V_{SS} = 0V$
Operating Temperature	T_{OP}	-20	70	°C	No Condensation
Storage Temperature	T_{ST}	-30	80	°C	No Condensation

Cautions:

Any Stresses exceeding the Absolute Maximum Ratings may cause substantial damage to the device. Functional operation of this device at other conditions beyond those listed in the specification is not implied and prolonged exposure to extreme conditions may affect device reliability.

3. Electrical Characteristics

3.1 DC Characteristics

$V_{SS}=0V, V_{DD}=5V, T_{OP}=25^{\circ}C$

Items	Symbol	MIN.	TYP.	MAX.	Unit	Applicable Pin
Operating Voltage	V_{DD}	4.8	5.0	5.2	V	VDD
Input High Voltage	V_{IH}	3.5	-	V_{DD}	V	RS, R/W, E, DB0-DB7
Input Low Voltage	V_{IL}	0	-	0.4	V	CSA, CSB, CSC
Operating Current	I_{DD}	-	6.0	18	mA	VDD, VSS

3.2 LED Backlight Circuit Characteristics

$V_{SS}=0V, I_{f_{BLA}}=120mA, T_{OP}=25^{\circ}C$

Items	Symbol	MIN.	TYP.	MAX.	Unit	Applicable Pin
Forward Voltage	$V_{f_{BLA}}$	-	5.0	-	V	BLA
Forward Current	$I_{f_{BLA}}$	-	-	120	mA	BLA

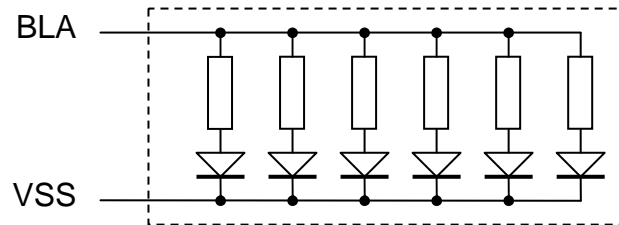

3.3 AC Characteristics

$V_{SS}=0V, V_{DD}=5V, T_{OP}=25^{\circ}C$

Item	Symbol	MIN.	TYP.	MAX.	Unit
E cycle time	tc	26	-	-	us
E high level width	twh	700	-	-	ns
E low level width	twl	700	-	-	ns
E rise time	tr	-	-	18	ns
E fall time	tf	-	-	18	ns
Address set-up time	tasu	240	-	-	ns
Address hold time	tah	50	-	-	ns
Data set-up time	tdsu	300	-	-	ns
Data delay time	td	-	-	480	ns
Data hold time (write)	tdhw	15	-	-	ns
Data hold time (read)	tdhr	30	-	-	ns

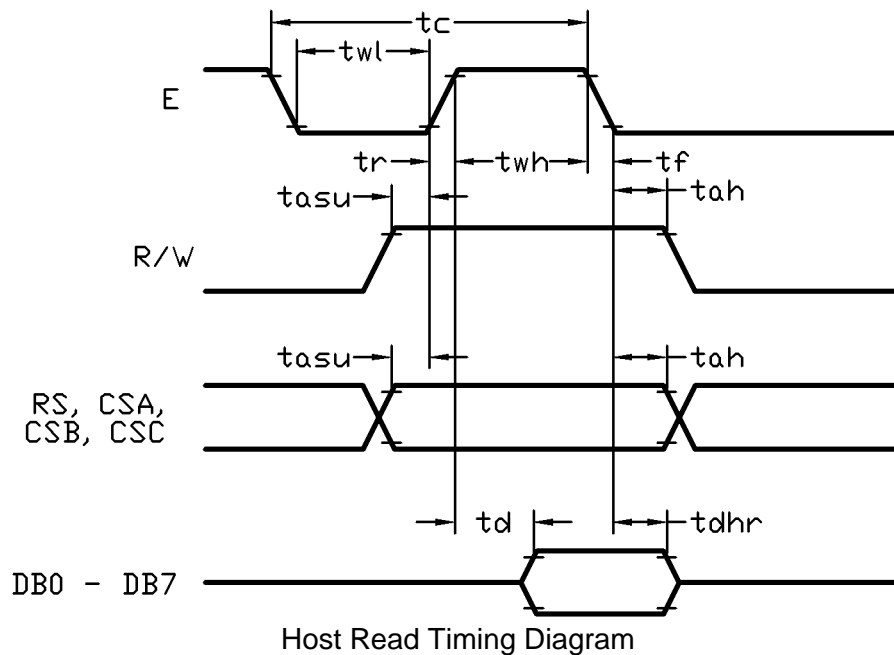
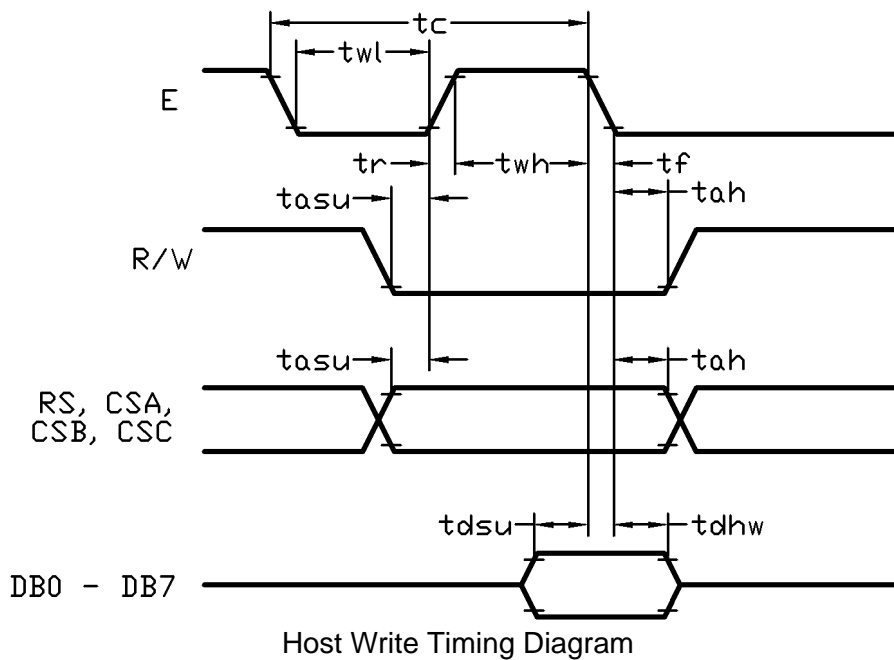

4. Function Specifications

4.1 Basic Setting

To drive the LCD module correctly and provide normally display, please use the following setting

Display start line (Z address)= 0
LCD Display = on

Note:

These setting/commands should issue to all controllers while start up.
See the Display Control Instructions section for details.

4.2 Adjusting the LCD display contrast

A Variable-Resistor must be connected to the LCD module for providing a reference to V0. Adjusting the VR will result the change of LCD display contrast.

The recommended value of VR is 25k to 50k

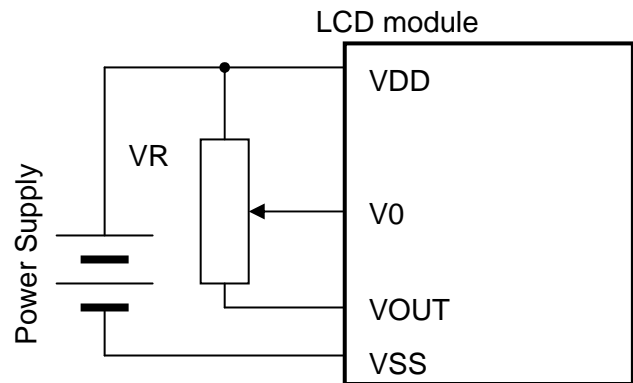

4.3 Resetting the LCD module

The LCD module should be initialized by setting /RST terminal at low level when turning the power on.

When /RST pull low, the LCD module will:

- Display off
- Display start line register becomes 0. (Z-address=0)

While /RST is low, no instruction can be accepted except status read. Therefore, execute other instructions after making sure that DB4=0 (clear /RST) and DB7=0 (ready) by status read instruction. The conditions of power supply at initial power up are as follow:

Item	Symbol	MIN.	TYP.	MAX.	Unit
Reset time	trs	2.0	-	-	us
Rise time	tr	-	-	150	ns

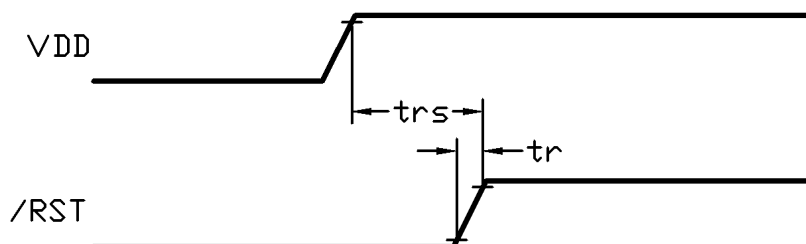

4.4 Display Memory Map

Page (X) address	data	LCD Display (front view)			
0	D0 ⋮ D7				
1	D0 ⋮ D7				
2	D0 ⋮ D7				
3	D0 ⋮ D7				
4	D0 ⋮ D7				
5	D0 ⋮ D7				
6	D0 ⋮ D7				
7	D0 ⋮ D7				
Column(Y) Address		00h → 3Fh	00h → 3Fh	00h → 3Fh	00h → 3Fh
Chip Select CSA		0	1	0	1
Chip Select CSB		0	0	1	1
Chip Select CSC		0	0	0	0

Note:

- 1) Display start line (Z address) = 0
- 2) The Display Data store separately in four drivers.

4.5 Internal Registers

There are three registers in each section of LCD module. Each of them could be controlled independently.

Page (X) Address Register

X address register designates pages of the internal display data RAM. Count function is not available. The address should set by instruction.

Column (Y) Address Counter

Y address counter designates address of the internal display data RAM. It could be set by instruction and increased by 1 automatically by read or write display data operations.

Display Start Line (Z) Register

Z address register indicates of display data RAM to LCD top line. It may be used for scrolling the display pattern on the LCD.

4.6 Display Control Instructions

Instructions	Code											Function	
	RS	R/W	DB7	DB6	DB5	DB4	DB3	DB2	DB1	DB0			
Display on/off	0	0	0	0	1	1	1	1	1	1	1/0	Controls the display on or off. Internal status and display data in RAM is not affected 0=off, 1=on	
Set Column (Y) Address	0	0	0	1	Y address (0-63)						0	Set the Column address into the Y address counter	
Set Page (X) Address	0	0	1	0	1	1	1	X address (0-7)				Set the Page address into the X address register	
Set Display Start Line (Z address)	0	0	1	1	Z address (0-63)						0	Indicates the display data RAM displayed at the top of the screen	
Status Read	0	1	Busy	0	on/off	Reset	0	0	0	0	0	Read status Busy=L, Driver ready; Busy=H, Driver busy on/off=L, Display is on; on/off=H, Display is off Reset=L, Normal Running; Reset=H, reset	
Write Display Data	1	0	Write data									0	Write display data into display data RAM, After writing instruction, Y address counter increased by 1 automatically
Read Display Data	1	1	Read data									0	Read display data form the display data RAM

Note:

- *1. For the details of the Display Control Instructions, please refer to Samsung SBN0064G handbook.

5. Design and Handling Precaution

1. The LCD panel is made by glass. Any mechanical shock (eg. dropping from high place) will damage the LCD module.
2. Do not add excessive force on the surface of the display, which may cause the Display color change abnormally.
3. The polarizer on the LCD is easily get scratched. If possible, do not remove the LCD protective film until the last step of installation.
4. Never attempt to disassemble or rework the LCD module.
5. Only Clean the LCD with Isopropyl Alcohol or Ethyl Alcohol. Other solvents (eg. water) may damage the LCD.
6. When mounting the LCD module, make sure that it is free from twisting, warping and distortion.
7. Ensure to provide enough space (with cushion) between case and LCD panel to prevent external force adding on it, or it may cause damage to the LCD or degrade the display result.
8. Only hold the LCD module by its side. Never hold LCD module by add force on the heat seal or TAB.
9. Never add force to component of the LCD module. It may cause invisible damage or degrade of the reliability.
10. LCD module could be easily damaged by static electricity. Be careful to maintain an optimum anti-static work environment to protect the LCD module.
11. When peeling off the protective film from LCD, static charge may cause abnormal display pattern. It is normal and will resume to normal in a short while.
12. Take care and prevent get hurt by the LCD panel sharp edge.
13. Never operate the LCD module exceed the absolute maximum ratings.
14. Keep the signal line as short as possible to prevent noisy signal applying to LCD module.
15. Never apply signal to the LCD module without power supply.
16. IC chip (eg. TAB or COG) is sensitive to the light. Strong lighting environment could possibly cause malfunction. Light sealing structure casing is recommend.
17. LCD module reliability may be reduced by temperature shock.
18. When storing the LCD module, avoid exposure to the direct sunlight, high humidity, high temperature or low temperature. They may damage or degrade the LCD module