

### FEATURES

- 32polyphonic playback at 44.1khz
- Advance Time Variable filter and
- amplitude control (ATFA)
- Advance Q PCM sound synthesis
- Built in Power management unit
- Built in Digital DAC interface
- Built in cpu, cpu program rom and data ram
- Dynamic voice assignment
- Supports up to 16Mx8 sampling memory (A0 ~A23)
- 100 pin CMOS QFP package

### General description

The QS1000 is a high performance digital signal processor, producing accurate, realistic musical sound. All the music synthesis algorithms are preset to make the most realistic acoustic sound and most control parameters can be changed during the creation of music according to the General MIDI specification. Also, built in HWASS proprietary decompression along with ATFA provides superb sound quality with compressed sound memory, thereby preserving sound quality and realism. The QS1000 is an ideal device to make sound generation (ex) Musical Instrument, Karaoke Machine, MIDI, Module, PC Sound card. ...etc)

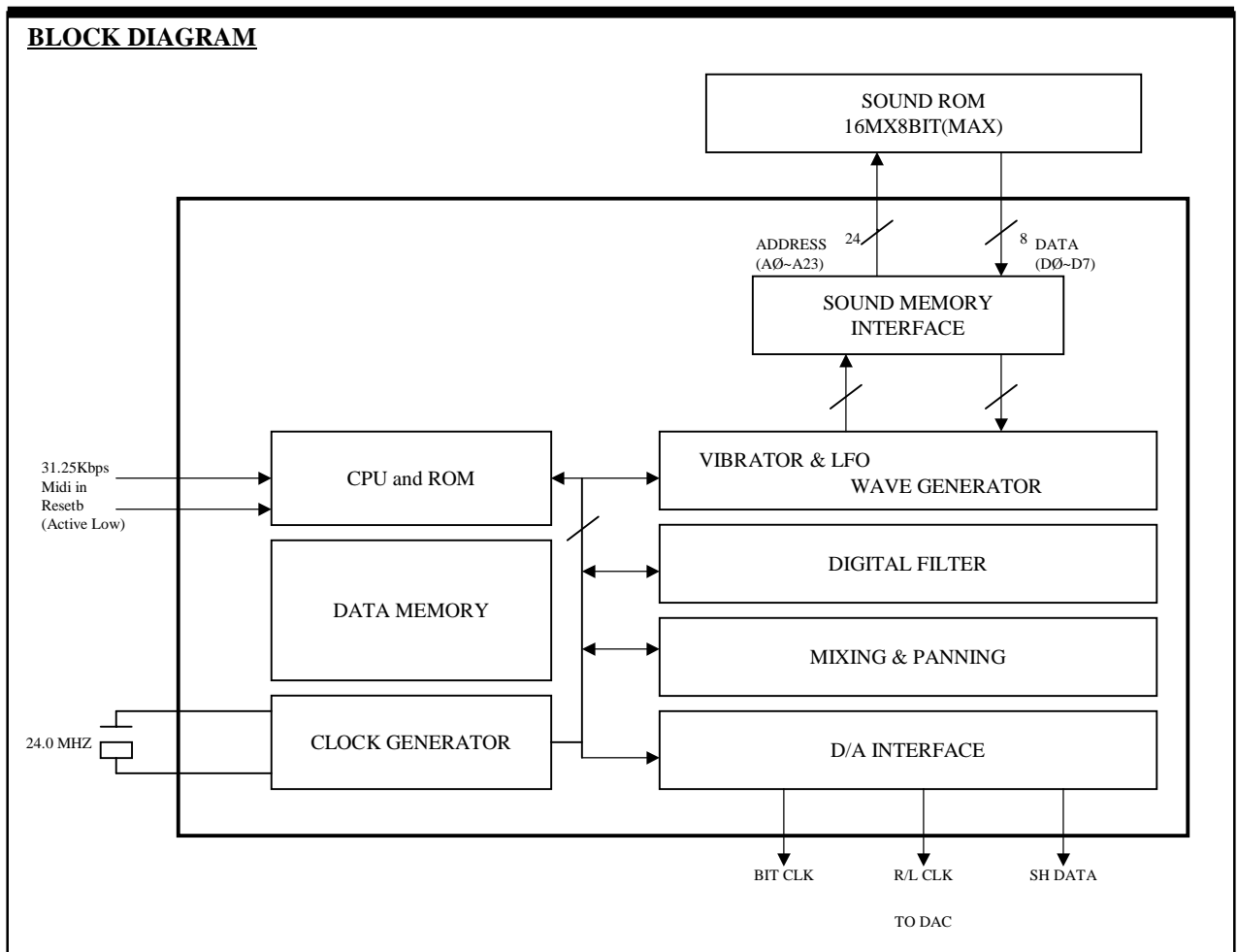

### FUNCTION OVERVIEW

The QS1000 is a specialized digital signal processor(QDSP which generate high quality, realistic sound. The QS1000 musical synthesizer contains all the necessary modules to create acoustic sound, and each module's parameters can be modified for individual voices during the creation of sound. To make best and simplest MIDI interpreter interface, QS1000 has an advanced parameter self-extracting module. Due to internal module, the 32 voices of music truly play back at 44.1khz without any play back frequency degradation or quality loss of sound.

The HWASS ATFA along with method are highly balanced to create functional module. All the functional module parameters are automatically extracted and modified without put commands during each voice of music generation. The Low Frequency Oscillator deeper timbre sensation to produce better effect sound. The high performance of the internal multistage filter with 128 different cutoff frequency levels along with 2-dimensional envelope generator make possible the closest recreation of acoustic sound.

The Qs 1000 automatic power management module is the most advanced control unit to archive maximum power saving during sound creation or DSP stand by operation mode. With this module, the device operating reliability is expanded beyond industrial specification and operational environment for all QS1000 application fields.

The use of HWASS Q-PCM technology, the 16 bit sound sampling data is compressed with 8:1 ratio, allows lower cost of sound memory without sound degradation.

The QS1000 decompression module reconverts the original true 16 bit sampled sound data using compressed sound data. The internal 16bit Q-PCM data produces the best quality of sound at 44.1khz playback by using internal 32 bit data paths for each module, along with an auto looping sequencer, which is capable of handling 1~1 million auto reload looping sequences, non-looping sequence, and one short looping sequence.

The QS1000 digital Q-filter is implemented to support variable frequencies for each voice from 12db to 96db to archive most optimal sound characteristic. With this Q-filter, each sound at playback can be produced more clearly and naturally with small amount of sound data; also, intriguing musical effects can be obtained by time varying filter control. Due to the high performance of the Q-filter, more realistic patch split, after-touch, and breath effects can be archive by cross mapping the Q-filter with either the by note or by velocity MIDI parameter.

The QS1000 cpu module contained all then necessary interface logic, cpu data memory, cpu program memory to minimize overall system integration cost. To achieve minimum cpu hand shake during operation time, all generation and recreation of sound parameters is done by self controlled hardware inside the module instead of depend upon cpu hand shake to receive internal synthesize parameters to continue sound generation operation

# HWA Sound Source Co., Ltd.

**QS1000**

## ASOLUTE MAXIMUM RATINGS (unless otherwise noted)

Parameter	Symbol	Min	Typ	Max	Unit
Ambient Temperature	-	-40		+85	°C
Storage Temperature	-	-65		+150	°C
Voltage on any pin to Vss	-	-0.5		Vcc+0.5	v
Supply Voltage	Vcc	2.8	4.5	5.5	v
Maximum IoL per I/O Pin	-	10	15	20	mA

## RECOMMENDED OPERATING CONDITIONS

Parameter	Symbol	Min	Typ	Max	Unit
Supply voltage	Vcc	3		5.5	V
Supply voltage	Vss		0		V
Operating free-air temperature	TA	0		70	°C

## DC CHARACTERISTICS (Over Operating Conditions)

Parameter	Symbol	Min	Typ	Max	Units
Input low voltage @Vcc=5.0V	VIL	0.5		1.5	V
Input high voltage @Vcc=5.0V	VIH	3.5		Vcc+0.5	V
Output low voltage at IOL=3.2mA, Vcc=5.0V	VOL			0.45	V
Output high voltage at IOH=0.8mA, Vcc=5.0V	VOL	2.4			V
Logical 0 input current at VIN=0.45v	IIL			-50	uA
Input leakage current at 0.45<VIN<VCC	ILI			+/-10	uA
Power supply current @Vcc=5.0V	Icc		5	20	mA

## EXTERNAL CLOCK CHARACTERISTICS

Pameter	Symbol	Min	Typ	Max	Units
Osciliator frequency	1/tCLCL		24		MHZ
High Time	tCHCX	15			ns
Low Time	tCLCX	15			ns
Rist Time	tCLCH			5	ns
TFall Time	tCHCL			5	ns

## AC CHARACTERISTICS(Over Operating Conditions)

Parameter	Symbol	Min	Typ	Max	Unit
Memory chip select Pulse With	tCSPW	850			ns
Memory Address Valid After CSB Low	tCSLAV		20		ns
Memory Data Valid Time After CSB Low	tAVDO			150	ns

## FORMAT OF DAC OUTPUT WAVEFORMS

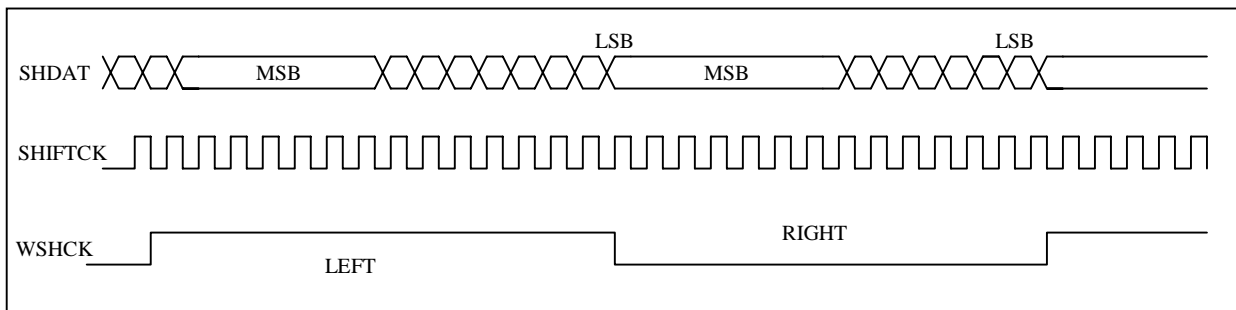

## EXTERNAL CLOCK WAVEFORM

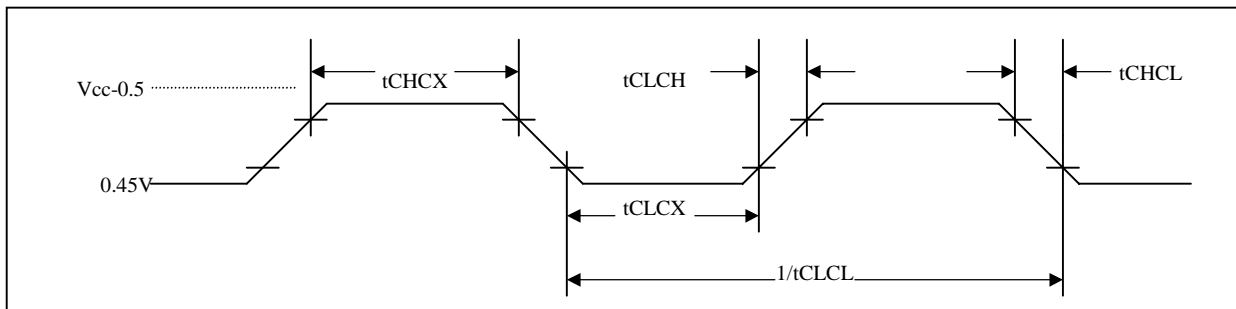

## SOUND MEMORY READ WAVEFORM

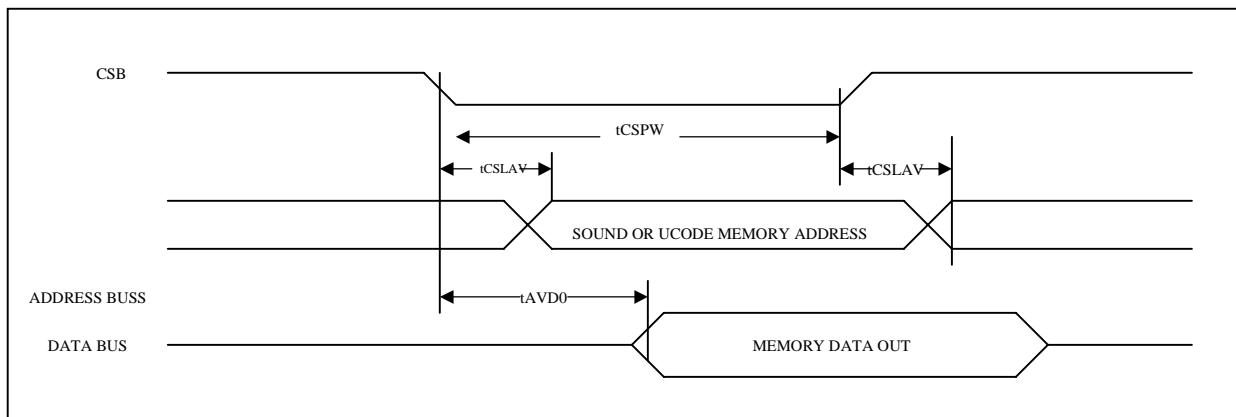

## APPLICATION OVERVIEW

The different QS1000 applications are available to implement cost effective solution to high performance of MIDI module, PC sound card, Karaoke, and Musical Instrument. To achieve each QS1000 application, The prearranged 1M byte GM sound library contains 128 standard instrument drum sets to implement GM and MT-32 GS format. Also special Piano and high performance of GM/ The QS1000 reference designs with schematics, bill of materials, and technical support are available to implement any level of system design.

## APPLICATION BLOCK DIAGRAM

(GM implement without recording function)

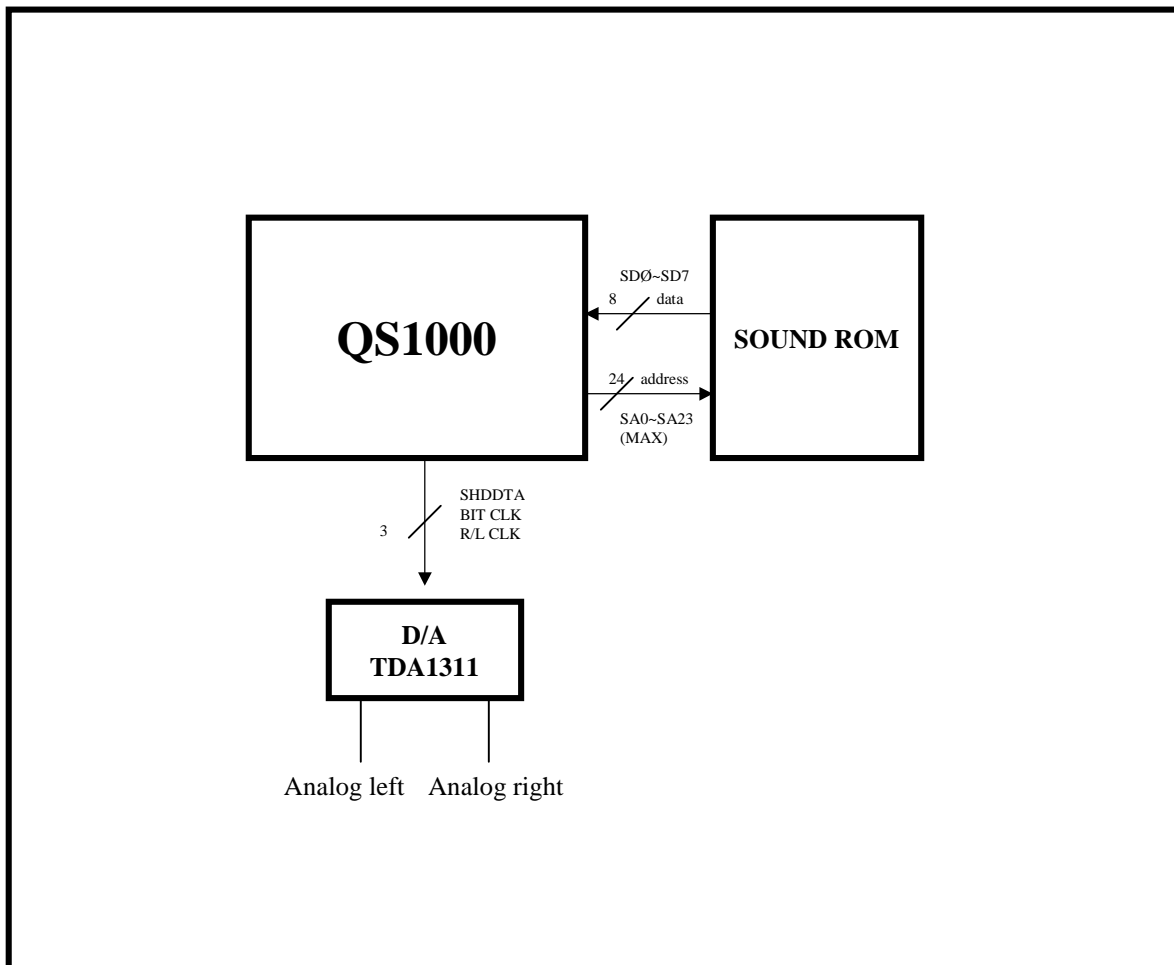

# HWA Sound Source Co., Ltd.

**QS1000**

## PIN DESCRIPTIONS

PIN NAME	PIN NUMBER	I/O	DESCRIPTION
CPU_D0-D7	20-24,26-28	I/O	Internal CPU data bus cpudata[7](MSB) through cpudata[0](LSB)*
MUTEMODE	5	I	Dac output mute enable pin (Active Low)
EX51ENB	6	I	External cpu enable pin(Active Low)
TESTMOD	7	I	Chip test mode enable pin(Active Low)
DAC16EN	8	I	16 bit dac output enable pin*(Table 1)
DAC18EN	9	I	18 bit dac output enable pin*(Table 1)
MRESETB	17	I	Dsp master reset active low input signal
MRESET	18	O	Dsp master reset signal Inverting output
EFF_CS	14	O	Effect processor chip select pin (optional pin)
RAM_CS	15	O	External extend ram chip select pin (optional pin)
R/L_CLK	11	O	Dac word clock signal
Bit CLK	12	O	Dac data shift clock signal
SHDATA	13	O	Dac serial data signal
SD0-7	58-65	I/O	Sound memory data bus SD7(MSB) through SD0(LSB)
SA[0-23]	67-71,73-76,78-82 84-91,93-94	O	Sound memory address bus SA23 (MSB) through SA0(LSB)
CK_SEL0-2	98,99,3	I	Clock input select mode select pin *(Table2)
XTAL1	1	I	Crystal & OSC input.
XTAL2	2	O	Xout
F45MIN	97	I	Optional external 45.1584MHz clock input pin
EA	19	I	Internal program rom or external program rom selection pin*
PORT10-17	40-47	I/O	8bit bidirectional I/O port*
PORT20-27	31-34,36-39	I/O	8bit bidirectional I/O port*
PORT30-37	49-56	I/O	8bit bidirectional I/O port*
VCC	4,16,48,66,77,92		5V power pins
VSS	10,25,35,57,72,83,96		Ground pins

\*Internal CPU8052 PIN

### <Table1> Master CLK Mode

	CK_SEL1(P99)	CK_SEL0(P98)	DESCRIPTION
Mode0	0	0	Used Internal 48 Mhz clk
Mode1	0	1	Used External 45.1584 clk Xin Pin97
Mode2	1	0	Used Exernal 48 Mhz clk

### CK\_SEL2(Pin3)

**1 : Internal 8052 Xin is Master CLK x 2**

**0 : Internal 8052 Xin is Master CLK x 1**

# HWA Sound Source Co., Ltd.

**QS1000**

**<Table2> DAC Selection mode**

DAC18EN(Pin9)	DAC16EN(Pin8)	Description	Remark
0	0	16 Bit mode(LSB First)	Recommend
0	1	18Bit mode(LSB First)	

## PIN CONFIGURATION

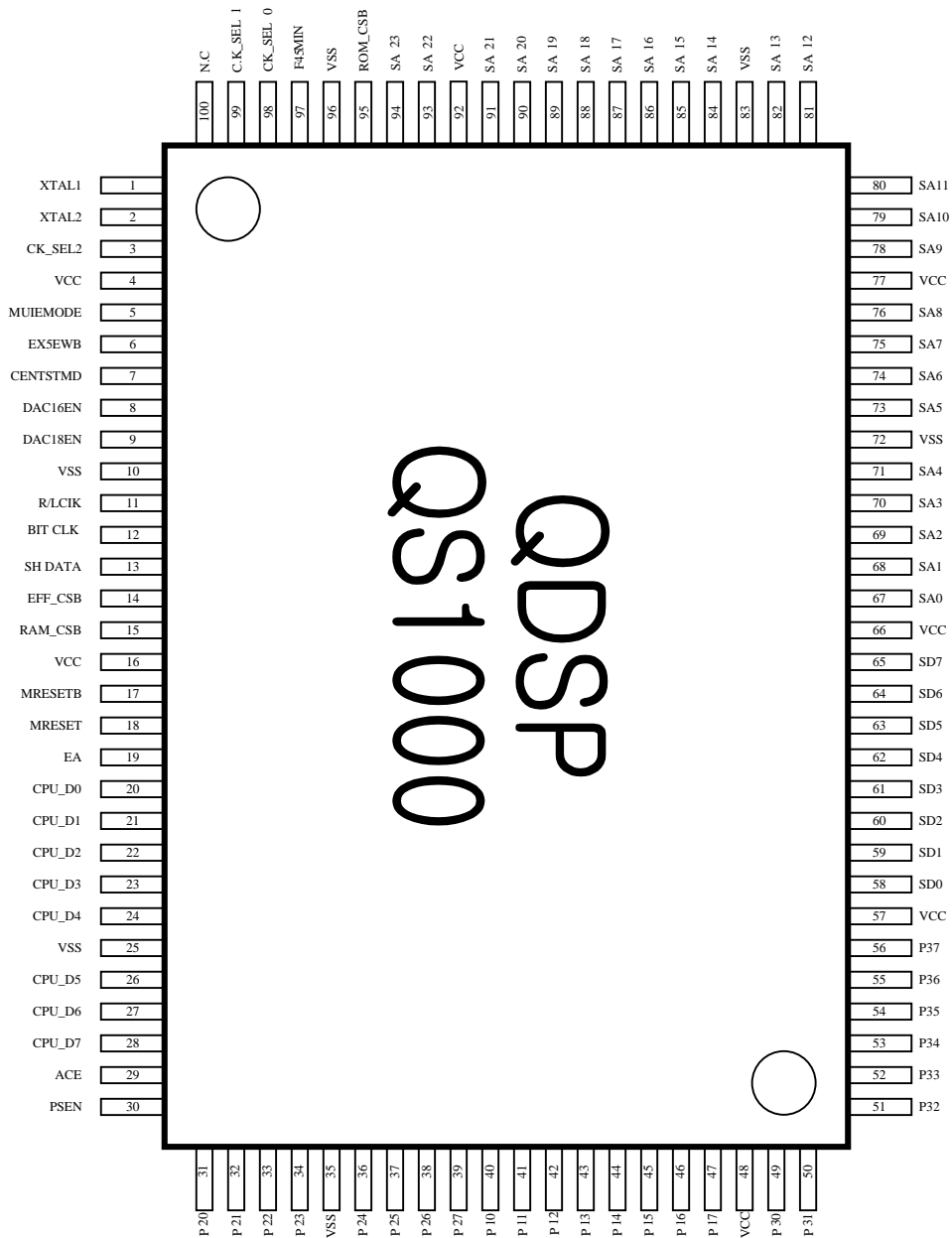



# HWA Sound Source Co., Ltd.

QS1000

## OUTLINE DIMENSIONS

Dimensions shown in millimeters

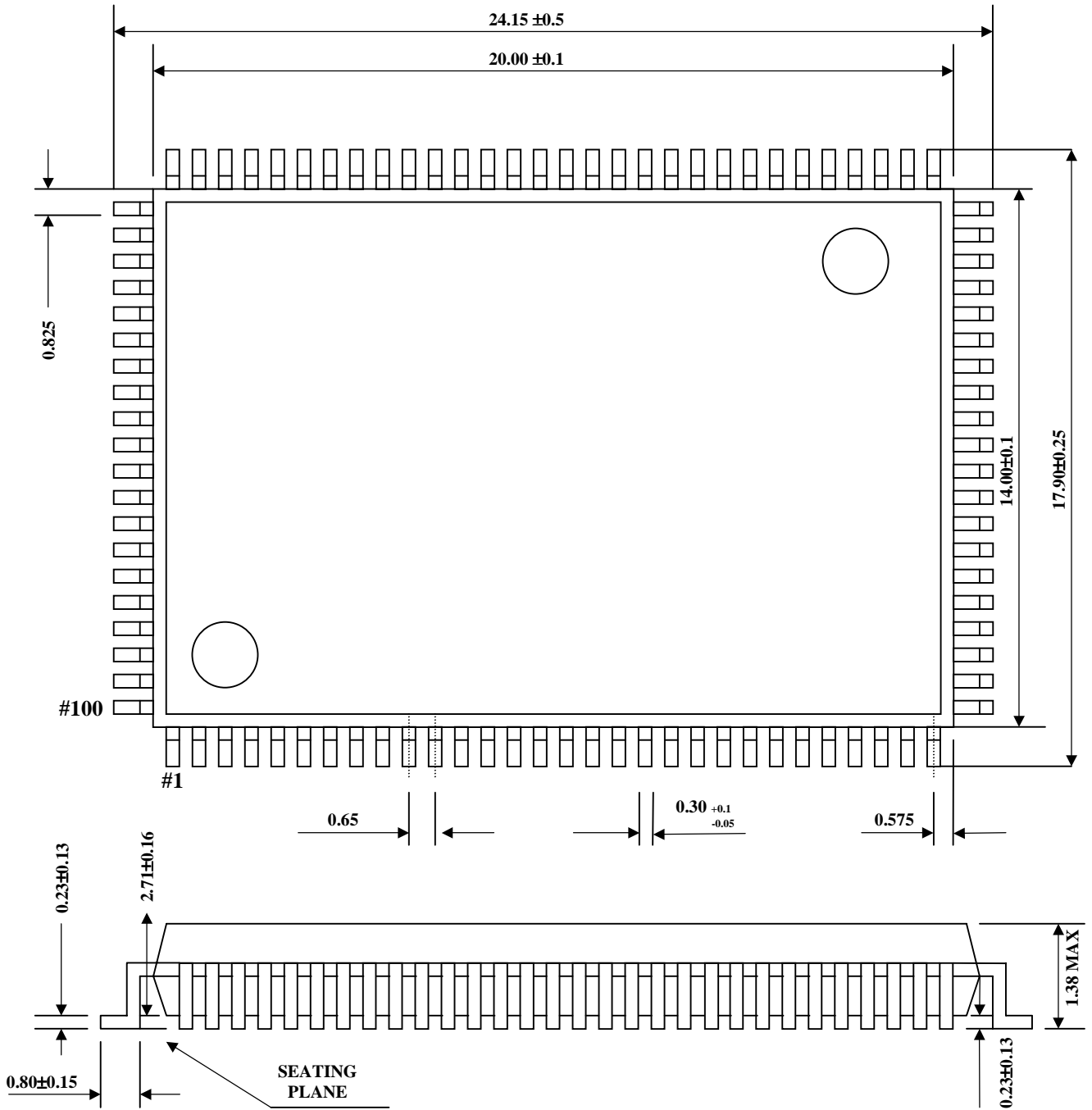

# HWA Sound Source Co., Ltd.

**QS1000**

## GENERAL MIDI SOUND SET :

PROG#	INSTRUMENT	PROG#	INSTRUMENT	PROG#	INSTRUMENT
1	Acoustic Grand Piano	51	SynthStrings 1	101	FX 5 (brightness)
2	Brigh Acoustic Piano	52	SynthStrings 2	102	FX 6 (goblins)
3	Electric Grand Piano	53	Choir Aashs	103	FX7 (echoes)
4	Honkey tonk Piano	54	Voice Oohs	104	FX 8 (sci-fi)
5	Electric Piano 1	55	Synth Voice	105	Sitar
6	Electric Piano 2	56	Orchestra Hit	106	Banjo
7	Harpichord	57	Trumpet	107	Shamisen
8	Clavi	58	Trombone	108	Koto
9	Celesta	59	Tuba	109	Kalimba
10	Glockenspiel	60	Muted Trumpet	110	Bag pipe
11	Music Box	61	French Hom	111	Fiddle
12	Vibraphone	62	Brass Section	112	Shanai
13	Marinba	63	SynthBrass 1	113	Tinkle Bell
14	Xylophone	64	SynthBrass 2	114	Agogo
15	Tubular Bells	65	Soprano Sax	115	Steel Drums
16	Dulcimer	66	Alto Sax	116	Woodblock
17	Drawbar Organ	67	Tenor Sax	117	Taiko Drum
18	Percussive Organ	68	Baritone Sax	118	Melodic Tom
19	Rock Organ	69	Oboe	119	Synth Drum
20	Church Organ	70	English Hom	120	Reverse Cymbol
21	Reed Organ	71	Bassoon	121	Guitar Fret Noise
22	Accordion	72	Clarinet	122	Breath Noise
23	Harmonica	73	Piccolo	123	Seashore
24	Tango Accordion	74	Flute	124	Bird Tweet
25	Acoustic Guitar (nylon)	75	Recorder	125	Telephone Ring
26	Acoustic Guitar (steel)	76	Pan Flute	126	Helicopter
27	Electric Guitar (jazz)	77	Blown Bottle	127	Applause
28	Electric Guitar (clean)	78	Shakuhachi	128	Gunshot
29	Electric Guitar (muted)	79	Whistle		
30	Overdriven Guitar	80	Ocarina		
31	Distortion Guitar	81	Lead 1 (square)		
32	Guitar harmonics	82	Lead 2 (sawtooth)		
33	Acoustic Bass	83	Lead 3 (calliope)		
34	Electric Bass (finger)	84	Lead 4 (chiff)		
35	Electric Bass (pink)	85	Lead 5 (charang)		
36	Fretless Bass	86	Lead 6 (voice)		
37	Slap Bass 1	87	Lead 7(fifths)		
38	Slap Bass 2	88	Lead 8(bass + lead)		
39	Synth Bass 1	89	Pad 1 (new age)		

# HWA Sound Source Co., Ltd.

## QS1000

Note Number	PC 1:STANDARD Set /PC 33:JAZZ Set	PC 9:ROOM Set	PC 17:POWER Set	PC 25: ELECTRONIC Set	PC 26 : TR-808 Set	PC 41 : BRUSH Set	PC 49 : ORCHESTRA Set
27	High Q						Closed Hi-Hat [EXC1]
28	Slap						Pedal Hi-Hat [EXC1]
29	Scratch Push [EX7]						Open Hi-Hat [EXC1]
30	Scratch Pull [EX7]						Ride Cymbal
31	Sticks						
32	Square Click						
33	Metronome Click						
34	Metronome Bell						
35	Kick Drum 2/Jazz BD2					Jazz BD2	Concert BD 2
36	Kick Drum 1/Jazz BD1		MONDO Kick	Elec BD	808 Bass Drum	Jazz BD1	Concert BD 1
37	Side Stick				808 Rim Shot		
38	Snare Drum 1		Gated SD	Elec SD	808 Snare Drum	Brush Tap	Concert SD
39	Hand Clap					Brush Slap	Castanets
40	Snare Drum 2			Gated SD		Brush Swirl	Concert SD
41	Low Tom 2	Room Low Tom 2	Room Low Tom 2	Elec Low Tom 2	808 Low Tom 2		Timpani F
42	Closed Hi-hat [EXC1]				808 CHH [EXC1]		Timpani F#
43	Low Tom 1	Room Low Tom 1	Room Low Tom 1	Elec Low Tom 1	808 Low Tom 1		Timpani G
44	Pedal Hi-hat [EXC1]				808 CHH [EXC1]		Timpani G#
45	Mid Tom 2	Room Mid Tom 2	Room Mid Tom 2	Elec Mid Tom 2	808 Mid Tom 2		Timpani A
46	Open Hi-hat [EXC1]				808 OHH [EXC1]		Timpani A#
47	Mid Tom 1	Room Mid Tom 1	Room Mid Tom 1	Elec Mid Tom 1	808 Mid Tom 1		Timpani B
48	High Tom 2	Room Hi Tom 2	Room Hi Tom 2	Elec Hi Tom 2	808 Hi Tom 2		Timpani c
49	Cymbal 1				808 Cymbal		Timpani c#
50	High Tom 1	Room Hi Tom 1	Room Hi Tom 1	Elec Hi Tom 1	808 Hi Tom 1		Timpani d
51	Ride Cymbal 1						Timpani d#
52	Chinese Cymbal			Reverse Cymbal*			Timpani e
53	Ride Bell						Timpani f
54	Tambourine						
55	Splash Cymbal						
56	Cowbell				808 Cowbell		
57	Crash Cymbal 2						Concert Cymbal 2
58	Vibra - slap						
59	Ride Cymbal 2						Concert Cymbal 1
60	High Bongo						
61	Low Bongo						
62	Mute High Conga				808 High Conga		
63	Open High Conga				808 Mid Conga		
64	Low Conga				808 Low Conga		
65	High Timbale						
66	Low Conga						
67	High Agogo						
68	Low Agogo						
69	Cabasa						
70	Maracas				808 Maracas		
71	Short Hi Whistle [EXC2]						
72	Long Low Whistle [EXC2]						
73	Short Guiro [EXC3]						
74	Long Guiro [EXC3]						
75	Claves				808 Claves		
76	High Wood Block						
77	Low Wood Block						
78	Mute Cuica [EXC4]						
79	Open Cuica [EXC4]						
80	Mute Triangle [EXC5]						
81	Open Triangle [EXC5]						
82	Shaker						
83	Jingle Bell						
84	Bell Tree						
85	Castanets						
86	Mute Surdo [EXC6]						
87	Open Surdo [EXC6]						
88							

PC : Program change number (drum set number)

Blank

: Same as the percussion sound of "STANDARD"

: No sound

[EXC]

: Percussion sound of the same number will not be heard at the same time.

# HWA Sound Source Co., Ltd.

QS1000

Note Number	PC 57:SFX Set
39	High Q
40	Slap
41	Scratch Push [EX7]
42	Scratch Pull [EX7]
43	Sticks
44	Square Click
45	Metronome Click
46	Metronome Bell
47	Guitar sliding finger
48	Guitar cutting noise (down)
49	Guitar cutting noise (up)
50	String slap of double bass
51	Fl. Key Click
52	Laughing
53	Screaming
54	Punch
55	Heart Beat
56	Footsteps1
57	Footsteps2
58	Applause
59	Door Creaking
60	Door
61	Scratch
62	Windchime
63	Car-Engine
64	Car-Stop
65	Car-Pass
66	Car-Crash
67	Siren
68	Train
69	Jetplane
70	Helicopter
71	Starship
72	Gun Shot
73	Machine Gun
74	Lasergun
75	Explosion
76	Dog
77	Horse-Gallop
78	Birds
79	Rain
80	Thunder
81	Wind
82	Seashore
83	Stream
84	Bubble

